

UNLESS OTHERWISE SPECIFIED

ERMCO COMPONENTS, INC.

DWG NO. 2A023043
 SH NUMBER OF SHS.
 TITLE: Clamp
 FIRST MADE FOR: 35 KV Bushing

SURFACES	TOLERANCES		
	2 PL DEC	3 PL DEC	ANGLES
✓	± .010	± .005	±

THE INFORMATION CONTAINED ON THIS DOCUMENT IS PROPRIETARY TO ERMCO COMPONENTS, INC. AND MAY NOT BE USED FOR ANY OTHER PURPOSES THAN THOSE EXPRESSLY AUTHORIZED BY ECI.

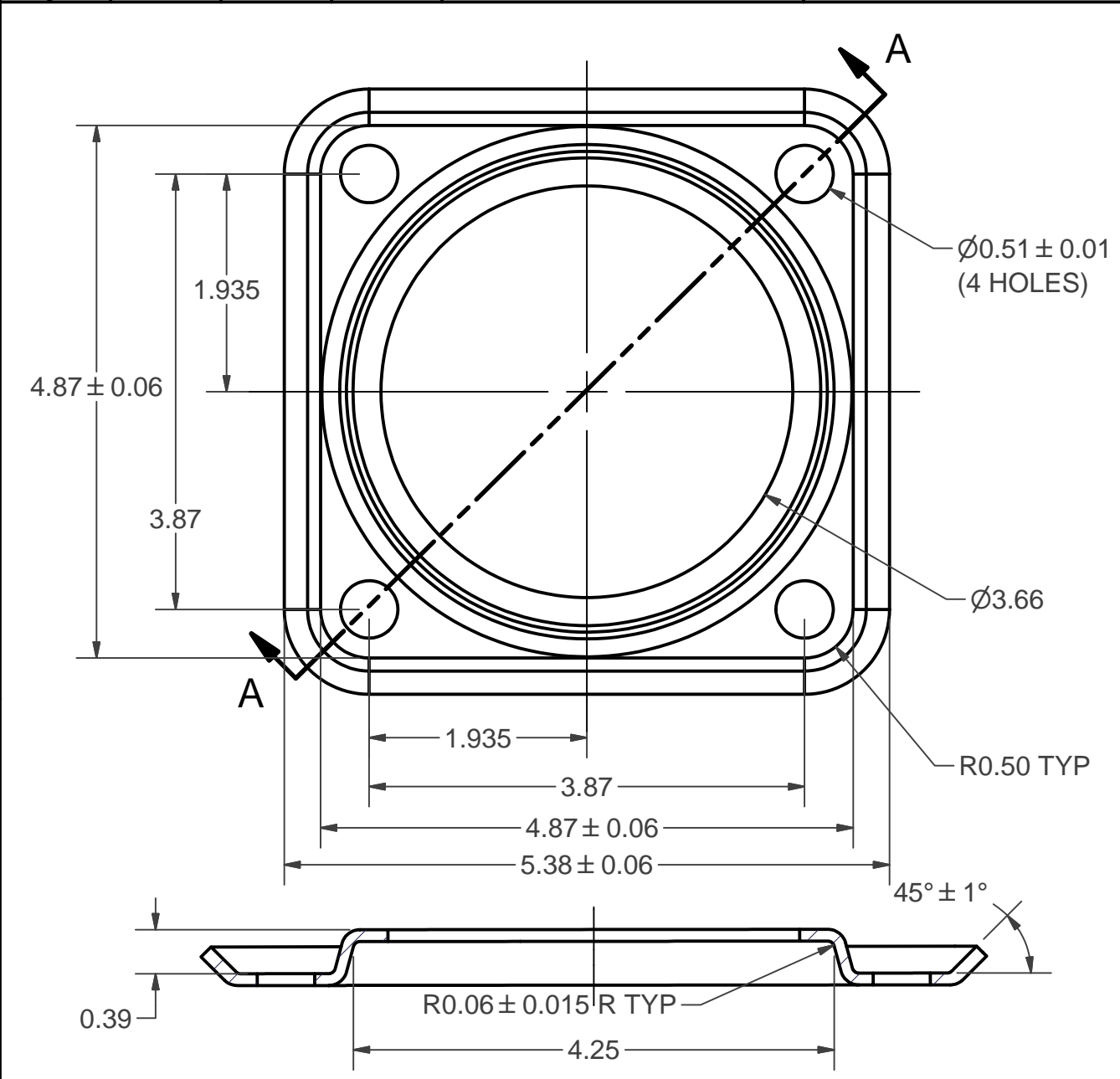

REVISIONS

REV	DESCRIPTION	DATE	BY
8	Updated into Inventor	28-Feb-00	Stuplin
9	Added catalog # for clamps ECN B945	14-July-95	B. Brittian

SECTION A-A

Gasket Catalog # 9U09AAW277

Part #	THK	Catalog # Clamp	Catalog # Clamp & Gasket	Material
01	.110	9U09AAW275	9U09AAW216	HR-LC STL Strip - Draw Quality B8A582 Except Rockwell "B" 60 Max (AISI 1008) (Zinc Chromate)
03	.100	9U09AAW276	9U09AAW262	CR-Chrom Nickle Stainless Steel Strip - Annealed - B7A65C3 (AISI Type 304)

10	N. Adams	10/20/04	Updated into Inventor
11	N. Adams	5/25/15	Added catalog # for clamps ECN B945

DRAWN BY: A. Millikan
 ECN 9/8/1980
 ISSUED BY: Nicholas Adams
 5/25/2015

APPROVAL
 ECI

DWG NO. 2A023043
 SH NUMBER OF SHS.
 TITLE: Clamp